

UID DPM COMPLIANCE VERIFIER

DPM Verifier

The DPM Verifier (for Direct Part Marks) is a UID Compliance Verifier that evaluates and verifies symbols according to specifications in MIL-STD-130 and DFAR 252.211-7003. The DPM Verifier is designed to analyze and verify Data Matrix symbols that are directly marked by dot peen, laser etch and chemical etch on materials such as metal, plastic, and rubber.

UID Compliance Verification products allow U.S. DoD (Dept. of Defense) suppliers and subcontractors to easily and consistently comply with a wide range of UID regulations.

Flexible Mounting

For maximum flexibility within any application or workspace, the DPM Verifier can be used as a standalone desktop unit, portable verifier or mounted to an optional stand.

Direct Part Marks

The DPM Verifier is designed for validation and verification of UID Data Matrix direct part marks with a variety of shapes and sizes. A variety of lighting options provide the necessary compliance for testing UID data syntax strings and evaluating symbol quality.

Reports

The DPM Verifier includes reporting features with quality assurance and repeatable/auditable results. Reports are detailed, and verification results are archived for back-up and compliance audits.

UID Compliance

Since implementation of the UID initiative, most goods destined for the U.S. DoD must be permanently marked with a UID code. UID Compliance Verifiers enable the DoD and their suppliers and subcontractors to meet the requirements in UID standards such as MIL-STD-130 and DFAR 252.211-7003.

Application Examples

U.S. DoD suppliers of:

- Aerospace parts
- Automotive parts
- Electronics
- Any UID Data Matrix direct part marks (laser, dot peen, chemical etch, photo etch, thermal print, etc.)



DPM Verifier: At a Glance

- Verification Standards:
 - ISO/IEC 16022
 - ISO/IEC 15415
 - AS9132
 - AIM DPM Guidelines
 - MIL-STD-130
- Ethernet Connectivity
- Easy One Button Calibration and Operation
- Secure Mode For Operation Within Secure Facilities

For more information on this product, visit www.microscan.com.

DPM Verifier: Available Codes

2D Symbols

Data Matrix



UID DPM COMPLIANCE VERIFIER SPECIFICATIONS AND OPTIONS

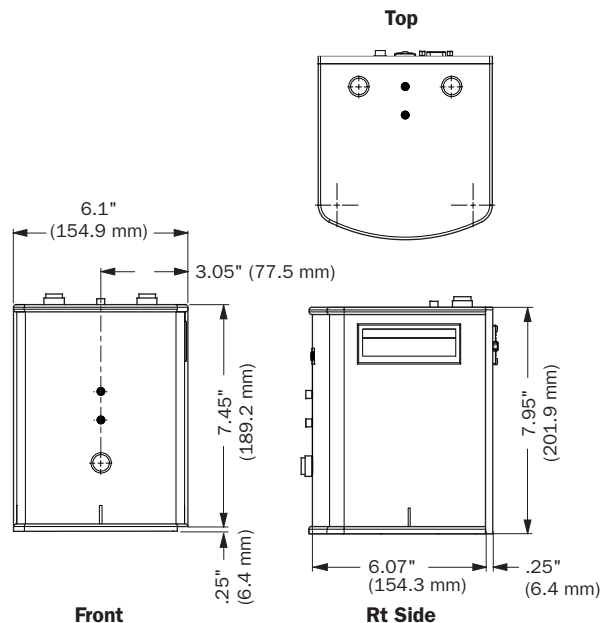

MECHANICAL

Height: 7.95" (201.9 mm)

Width: 6.1" (154.9 mm)

Length: 6.07" (154.3 mm)

READ PARAMETERS

Image Field: 1.19" x 0.86" (30.2 mm x 21.8 mm)

Min. Element Size: 0.0075" (0.19 mm)

ELECTRICAL

Power: AC adapter 100 to 240 VAC, 1.6 A
50/60 Hz input, 24 V with 1.5 A output

COMMUNICATIONS PROTOCOLS

Standard Interface: Ethernet

Maintenance Purposes: RS-232

ENVIRONMENTAL

Operating Temperature: 0° to 40° C (32° to 104° F)

Humidity: Up to 95% (non-condensing)

LIGHT SOURCE

Type: Class I LED, Red LED

External: 640 nm

Diffuse Perpendicular 90°

Dome (D)

Medium Angle 45° (45Q)

Low Angle 30° (30Q, 30T and 30S)

EMISSIONS/IMMUNITY

Heavy Industrial Immunity: EN 61010-1: 2002

Lead Radiation CCS: EN 60825-1 1993

Amendment 2 2001-01

MINIMUM PC REQUIREMENTS

- Host PC running Microsoft Windows 2000, Windows XP, or Windows Vista
- At least a 2 GHz CPU
- At least 512 MB RAM
- CD-ROM drive
- At least 100 MB of available hard disk space
- A 10/100 MB Network (Ethernet) interface
- Display capable of displaying at least 1024 by 768 pixels, true colors

SYMBOLS VERIFIED

Data Matrix (ECC 0-200)

STANDARDS

- AIM DPM-1-2006
- ISO 16022
- ISO 15415
- ISO 15434
- ISO 15418
- SAE AS9132 Laser
- SAE AS9132 Dot Peen
- SAE AS9132 Electro-Chemical Etch
- DFAR 252.211-7003
- MIL-STD-130L
- MIL-STD-130L Change 1
- MIL-STD-130M
- MIL-STD-130M Change 1
- MIL-STD-130N
- Guide to Uniquely Marking Items Version 1.4
- Guide to Uniquely Marking Items Version 1.5
- Guide to Uniquely Marking Items Version 1.6
- ATA SPEC200 Chapter 9 and ANSI MH10

SAFETY CERTIFICATIONS

FCC, UL/cUL, CE, CB

ISO CERTIFICATION

Certified ISO 9001:2000 Quality Management System

©2009 Microscan Systems, Inc. SP040C 08/09
Performance data is determined using high quality Grade A symbols per ISO/IEC 15415 and ISO/IEC 15416 in a 25°C environment. For application-specific results, testing should be performed with symbols used in the actual application. Microscan Applications Engineering is available to assist with evaluations. Results may vary depending on symbol quality. **Warranty**—One year limited warranty on parts and labor. Extended warranty available.

MICROSCAN®

Microscan Systems Inc.

Tel 425 226 5700 / 800 251 7711

Fax 425 226 8250

Microscan Europe

Tel 31 172 423360 / Fax 31 172 423366

Microscan Asia Pacific

Tel 65 6846 1214 / Fax 65 6846 4641

www.microscan.com

Product Information: info@microscan.com

Auto ID Support: helpdesk@microscan.com

Vision Support: visionsupport@microscan.com

NERLITE Support: nerlitesupport@microscan.com